

**Servogetriebe**  
Servo Gears

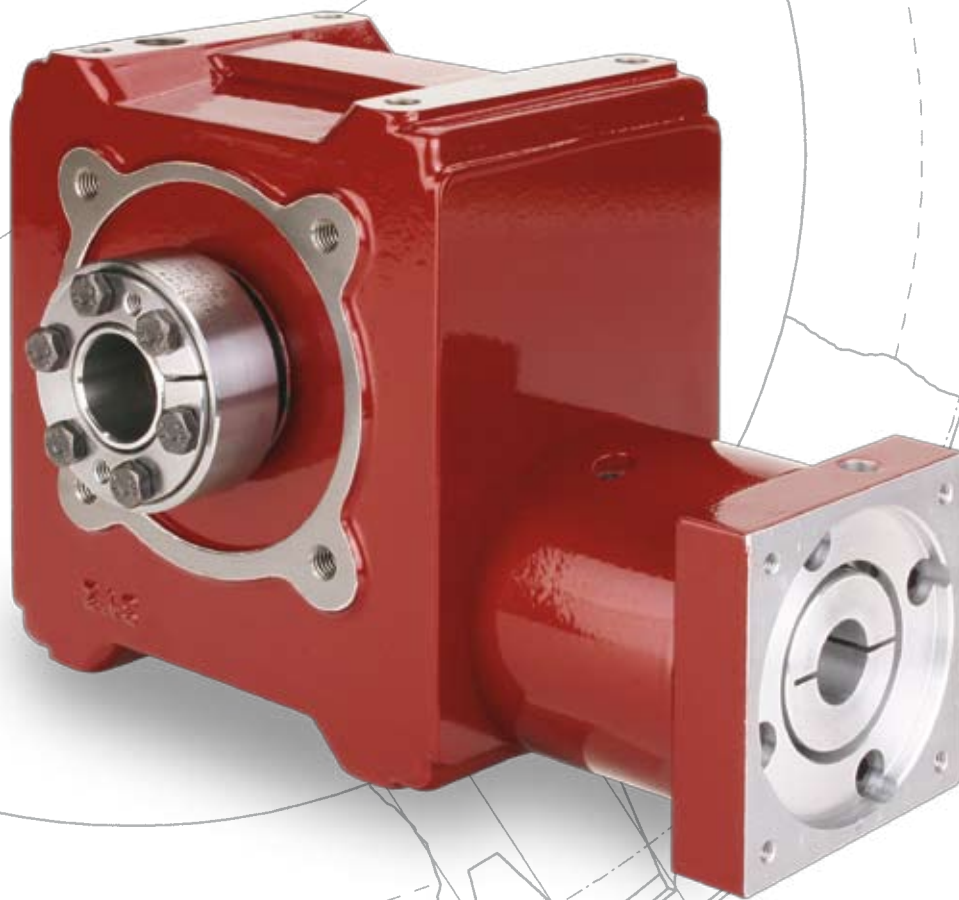

P2



ANTRIEBS SYSTEME

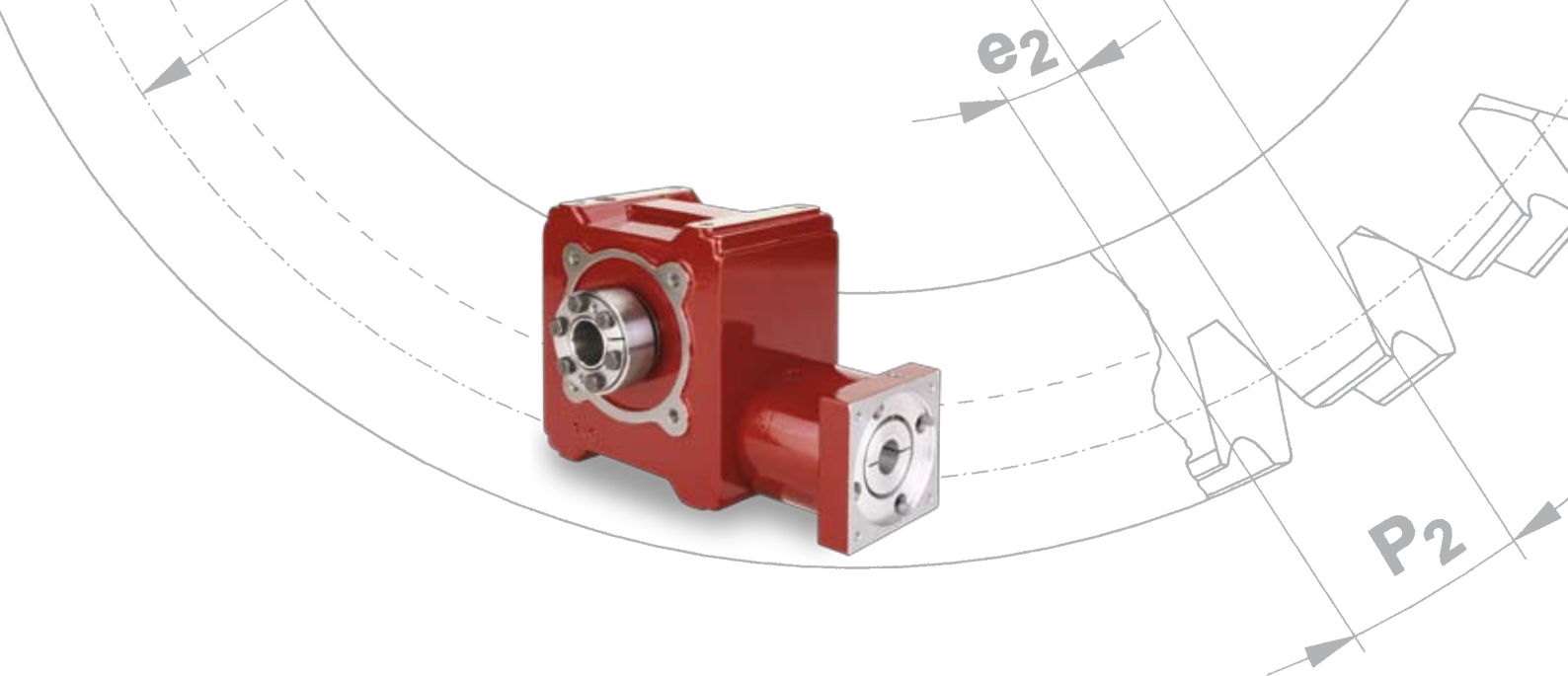

### ZAE SERVO WINKELGETRIEBE

- Antriebsseite:
  - Individuell für jeden Servomotor vorbereitet
  - Optional zweites Antriebswellenende
  
- Abtriebsseite:
  - 5 verschiedene Ausführungen
  - Hohlwelle mit Nut
  - Hohlwelle mit Schrumpfscheibe ein- oder beidseitig
  - Abtriebswelle ein- oder beidseitig

### ZAE RIGHT ANGLE SERVO GEARS

- Input side:
  - individual prepared for every Servo motor
  - Optional second inputschaft
  
- Output side:
  - 5 various executions
  - Hollow outputshaft with keyway
  - Hollow outputshaft with shrinkdisc on one or both sides
  - Outputshaft on one or both sides

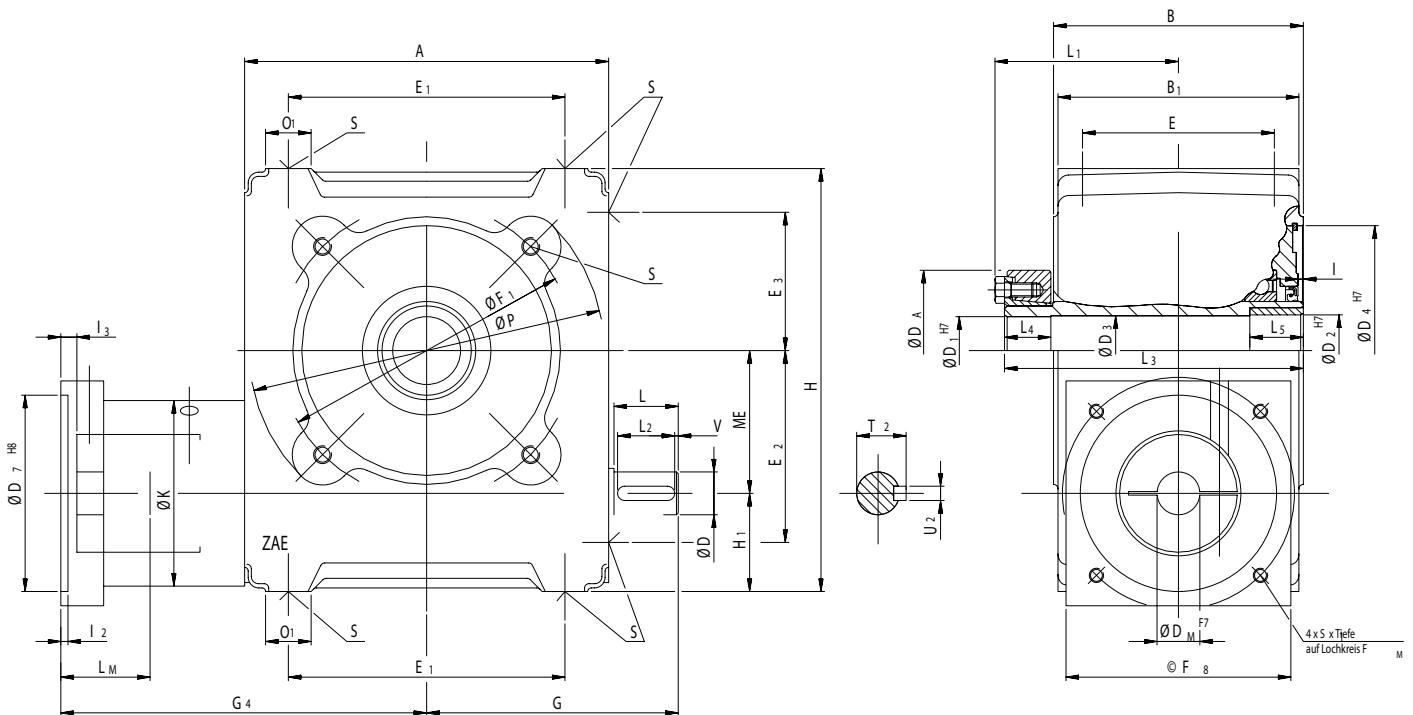

## BEWÄHRTE ZAE QUALITÄT FÜR DIE SERVOTECHNIK

### Kompakte ZAE Servo Winkelgetriebe (in spielarmer Ausführung)

- Hohe Laufruhe durch optimale Werkstoffpaarung
- Hohe Übersetzungen in einer Stufe
- Hervorragende Schwingungs- und vibrationsdämpfende Eigenschaften
- Universelle Einbaulage
- Synthetische Lebensdauerschmierung, optional mit lebensmittelverträglichem Syntheseöl
- Verdrehsteife Metallbalgkupplung

## RECOGNIZED ZAE QUALITY FOR THE SERVO TECHNOLOGY

### Compact ZAE Servo gears in right angle design (low backlash)

- Silent running achieved by optimal combination of materials
- High ratio in a single stage
- Excellent vibration absorbing characteristics
- Universal mounting
- Lifetime lubrication with synthetic oil, optional with synthetic oil for food and beverage industry
- Torsionally stiff steel bellow coupling

Typ ME	A	D	L	$D_2^{H7}$	E	$E_2$	$F_1$	H	$L_2$	$O_1$	S	$U_{2\text{H9}}$	L3	$D_A$	$D_M^{F7}$	$L_M$
	B			$D_3$									L4			
	$B_1$	$D_{1k6}$	$L_1$	$D_4^{H7}$	$E_1$	$E_3$	G	$H_1$	I	P	$T_2$	V	L5		K	$G_4$
S 040 40	104	14	24	22	70	55	85	124	20	14	M6x12	5	114	50	$8_{\min} - 20_{\max}$	$40_{\max}$
	90			20									19			
	85	20	73	70	70	35	79	32	3	53	16	1.5	19		70	126
S 050 50	140	16	28	27	80	70	110	160	25	18	M8x14	5	130	60	$8_{\min} - 20_{\max}$	$40_{\max}$
	105			25									21			
	100	25	81.5	90	100	50	100	40	3	65	18	1.5	21		84	145
S 063 63	164	18	28	32	95	87.5	130	190	25	18	M8x14	6	147.5	72	$11_{\min} - 30_{\max}$	$50_{\max}$
	120			30									23			
	115	30	92.8	110	125	62.5	113	45	3	80	20.5	1.5	24		95	170
S 080 80	204	24	36	40	115		165	237	32	22	M10x17	8	167.5	90	$18_{\min} - 38_{\max}$	$60_{\max}$
	140			38.6									27			
	135	38		140	155	77.5	141	55	3	100	27	2	29		104	210

Die Maße  $D_7$ ;  $F_M$ ;  $F_8$ ;  $I_3$ ;  $I_2$  und  $S_1$  sind vom anzubauenden Motor abhängig und werden motorspezifisch angepasst.  
Dimensions  $D_7$ ;  $F_M$ ;  $F_8$ ;  $I_3$ ;  $I_2$  and  $S_1$  depend on motortype and -size.

# ZAE Servogetriebe

## ZAE Servo Gears

Baugröße / size		40	50	63	80	
Nenn Drehmoment am Abtrieb nominal output torque  (n 1 = 1500 1/min)	i = 5	41	95	143	251	T <sub>zul</sub> [Nm]
	i = 7.5	45	104	157	277	
	i = 10	43	91	170	297	
	i = 13.3	32	59	135	187	
	i = 15	48	106	156	263	
	i = 20	50	106	182	296	
	i = 26.5	38	76	173	245	
	i = 30	50	105	153	259	
	i = 40	56	115	179	292	
Nenn Drehmoment am Abtrieb nominal output torque  (n 1 = 3000 1/min)	i = 5	33	70	92	134	T <sub>zul</sub> [Nm]
	i = 7.5	36	74	98	152	
	i = 10	39	85	121	179	
	i = 13.3	31	55	125	173	
	i = 15	37	71	95	148	
	i = 20	43	81	116	173	
	i = 26.5	36	71	132	208	
	i = 30	36	70	94	146	
	i = 40	44	80	114	171	
max. Antriebsdrehzahl / max. input speed		5000	5000	4000	4000	min <sup>-1</sup>
Nenn Drehzahl / nominal input speed		3500	3500	3000	3000	min <sup>-1</sup>
Verdrehflankenspiel reduziert* / backlash reduced*		≤ 6'	≤ 6'	≤ 6'	≤ 6'	j
Lebensdauer / service life		12.000	12.000	12.000	12.000	Lh [h]
Wirkungsgrad unter Vollast efficiency under load  (n 1 = 3000 1/min)	i = 5	0.94	0.96	0.96	0.96	
	i = 7.5	0.92	0.94	0.94	0.95	
	i = 10	0.91	0.93	0.94	0.94	
	i = 13.3	0.88	0.90	0.93	0.93	
	i = 15	0.86	0.88	0.89	0.90	
	i = 20	0.84	0.87	0.88	0.89	
	i = 26.5	0.80	0.84	0.86	0.88	
	i = 30	0.75	0.79	0.80	0.82	
	i = 40	0.72	0.76	0.78	0.80	
Gewicht (ca.) / weight		7	12	18	28	m[kg]
Zulässige Getriebetemperatur permissible gear reducer temperature		85				°C
Schmierung / lubrication		synth. Getriebeöl ISO VG220 / synthetic oil ISO VG220				

\* optional



© ZAE-AntriebsSysteme GmbH & Co KG

Schützenstraße 105 ▪ D-22761 Hamburg

T +49 (0)40/85393-03 ▪ F +49 (0)40/85393-232

info@zae.de ▪ www.zae.de